

CICLOMEC 1000

Automatic high production metal cutting machine with a high cut quality in tolerance and squareness, adapt for any kind of solid bars as well as tubes in round, square or rectangular section or profiles.

Round tube: from \varnothing 10mm, to \varnothing 100mm (optional: max \varnothing mm 120);

Square tube: from 10 x 10mm, to 100 x 100mm (optional: max 110 x 110);

Rectangular: from 10 x 10mm, to 120 x 100mm;

Bar: from \varnothing 8mm, to \varnothing 60mm.

HEADS TIPE

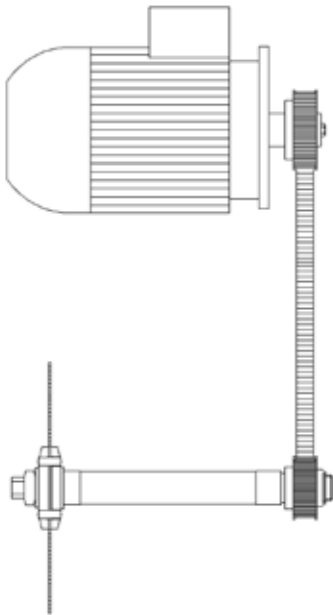

LIGHT CUTTING HEAD

- ▶ Vertical cutting descending from above saw head mounted on prismatic guides, with possibility of adjusting any possible play between the slides and the head, with automatic centralized lubrication.
- ▶ Suitable for light alloys (aluminum, brass, copper).
- ▶ Blade speed up to 4000 rpm.
- ▶ TCT blade.
- ▶ Electronic blade protection device which can be adjusted according to needs.
- ▶ Blade diameter: min 200 mm - max 350 mm.
- ▶ Oil mist blade lubrication.

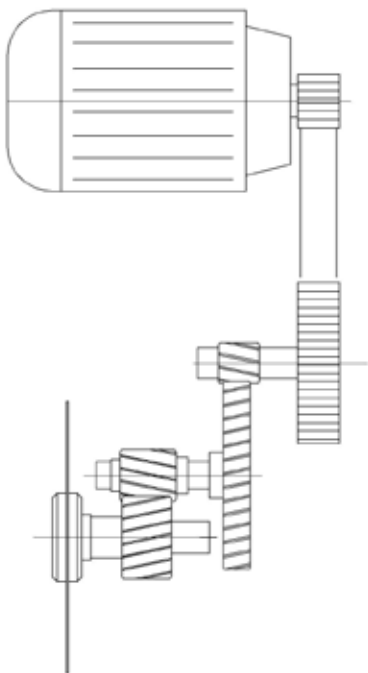

HEAVY CUTTING HEAD

- ▶ Vertical cutting descending from above saw head mounted on prismatic guides, with possibility of adjusting any possible play between the slides and the head, with automatic centralized lubrication.
- ▶ Suitable for steel, stainless steel, ECOBRASS.
- ▶ Composed with hardened and ground helicoidal gears to obtain an high operating rate, without any play or vibration of the saw blade.
- ▶ Blade speed from 30rpm to 400rpm with the possibility to mount an inverter to adjust the blade speed while the machine is operating.
- ▶ Conventional type blades as well as TIN type
- ▶ Worn HSS blade can be re-sharpened.
- ▶ Diameter the blade min \varnothing 200 mm - max: 350 mm.
- ▶ Oil mist blade lubrication.

MACHINE DEVICES



- ▶ CN feeding gripper powered by a servo motor, with a stroke of 1000 mm, with possibility of duplications for longer pieces.
- ▶ Feeding gripper speed 1 m/s.
- ▶ Manual adjustment on the clamping device according to the diameter or the profile to be cut.
- ▶ Pneumatic clamping in both side of the blade.
- ▶ Centralized lubrication system for the moving parts.
- ▶ Electronic equipment Siemens with Siemens touch screen interface.

LOADERS TYPE

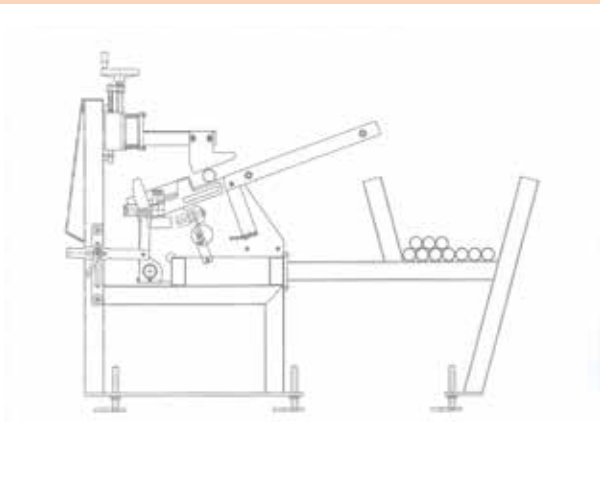

AUTOMATIC SLOPE LOADER "M"

- ▶ Suitable for the following material dimension:
 - ▶ Round tubes from \varnothing 6mm to \varnothing 90mm.
 - ▶ Square tubes from 10x10mm to 100x100mm.
 - ▶ Rectangular tubes from 10x10mm to 120x80mm.
 - ▶ Wall thickness up to 5mm for steel and stainless steel.
- ▶ Tube length from 2.5m to 6.5m (optional up to 9m).
- ▶ Loader gripper to feed the material into the machine.
- ▶ Load capacity limited to the inclined chute.
- ▶ Loader support to position the material on the inclined plane.

Others options will be indicated in an official quote.

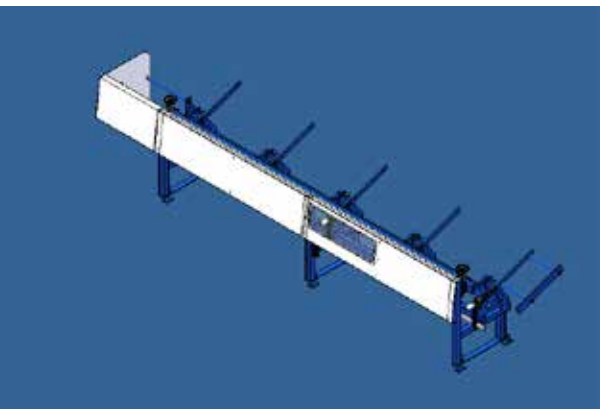

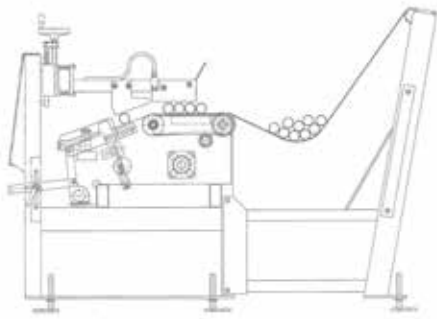

HEAVY CUTTING HEAD

- ▶ Vertical cutting descending from above saw head mounted on prismatic guides, with possibility of adjusting any possible play between the slides and the head, with automatic centralized lubrication.
- ▶ Suitable for steel, stainless steel, ECOBRASS.
- ▶ Composed with hardened and ground helicoidal gears to obtain an high operating rate, without any play or vibration of the saw blade.
- ▶ Blade speed from 30rpm to 400rpm with the possibility to mount an inverter to adjust the blade speed while the machine is operating.
- ▶ Conventional type blades as well as TIN type
- ▶ Worn HSS blade can be re-sharpened.
- ▶ Diameter the blade min \varnothing 200 mm - max: 350 mm.
- ▶ Blade lubrication and cooling system.

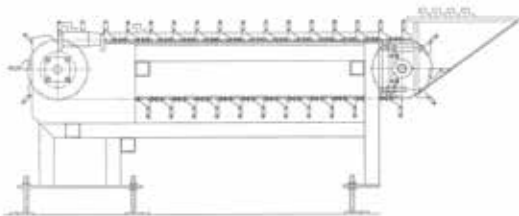
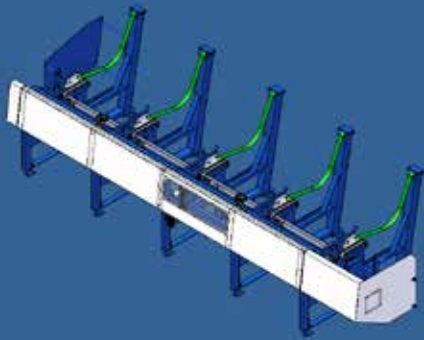

AUTOMATIC CHAIN LOADER CM

- ▶ Suitable for the following material dimension:
 - ▶ Round tubes from \varnothing 6mm to \varnothing 100mm.
 - ▶ Square tubes from 8x8mm to 100x100mm.
 - ▶ Rectangular tubes from 10x10mm to 120x80mm.
 - ▶ Special profile (external dimension max 120x80mm).
- ▶ Tube length from 2,5m to 6,5m.
- ▶ Manual load of the profile in the loader.
- ▶ Security device to allow the manual loading in the spaces.
- ▶ Automatic in-feeding device from the loader chain into the cutting machine.
- ▶ Loader gripper to feed the material into the machine.
- ▶ Customized n° of teeth in the chain according with the profile dimension.

There is another customized loader available to cut brass; for more information, please enter your data in the RESERVED AREA.

UNLOADING DEVICES

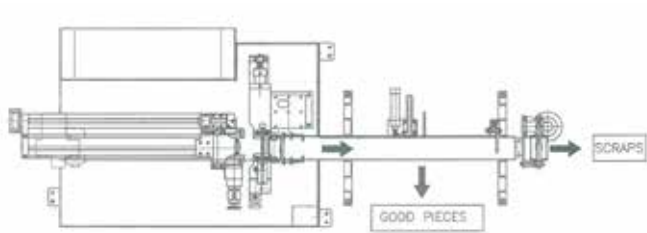

UNLOADING BELT T1

- ▶ Automatic unloading belt with one discharge position (one side) plus another one for trim cut and scraps.
- ▶ Pneumatic pusher to discharge the pieces.
- ▶ Trim cut and scrap goes straight to the end on the belt.
- ▶ For pieces up to 1m (possibility to extend the unloading length).

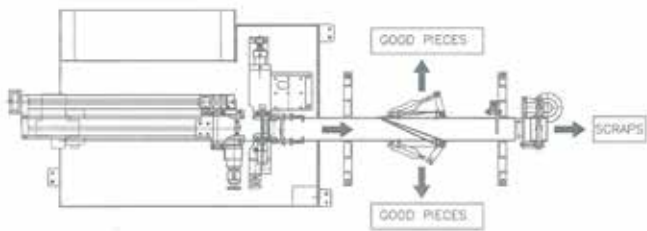

UNLOADING BELT T2

- ▶ Automatic unloading belt with two discharge position plus another one for trim cut and scraps.
- ▶ Two deflectors controlled by the panel to manage the unloading system.
- ▶ Pneumatic pusher to discharge the pieces on both sides.
- ▶ Trim cut and scrap goes straight to the end of the belt.
- ▶ For pieces up to 1m (possibility to extend the unloading length).

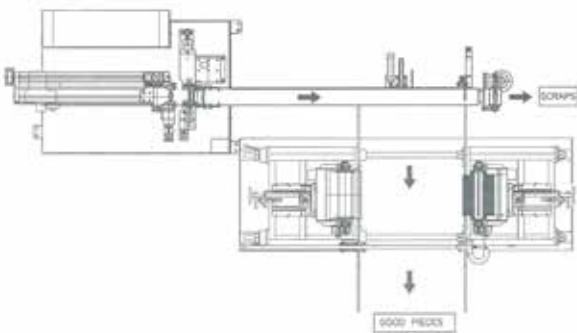

UNLOADING BELT T3

- ▶ Automatic unloading belt to discharge pieces into a deburring machine.
- ▶ For pieces up to 1m (possibility to extend the unloading length).
- ▶ Other information available on the reserved area.

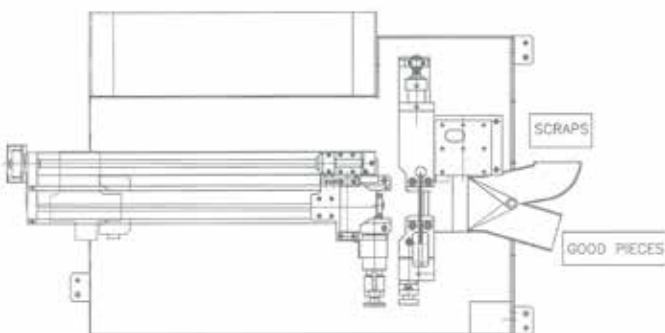

UNLOADER DEFLECTOR

- ▶ Proper for short pieces.
- ▶ Pneumatic movement of the deflector to divide good pieces from scraps.

All the other CICLOMEC 1000 options, will be available in an official quote.